



Equipment Catalog

- **Cost Effective**
- **Innovative Designs**
- **Built-to-Last!**



Manufactured by:

BENKO PRODUCTS
ENGINEERED TO BE MORE

Benko Products Inc. · 5350 Evergreen Pkwy · Sheffield Village, Ohio · 44054
Phone (440) 934-2180 · Fax (440) 934-4052 · e-mail: sales@benkoproducts.com
---- www.BenkoProducts.com ----



For more than 50 years, GREEN Access & Fall Protection has been designing and building the industry's leading solutions for providing safe access in both tank truck and railcar applications. After five decades in the business, tens of thousands of GREEN units are currently used in service including innovative products such as the GREENLINE Self-Leveling Stairs which were pioneered by GREEN, as well as the G-Raff Elevating Platform, often considered the best elevating platform in the industry.

Proudly made in the USA, the GREEN Access & Fall Protection line is manufactured by Benko Products, Inc., located in Sheffield Village, OH. Our long history of proven installations in every type of access and fall protection application means that Benko Products, Inc. is **the** manufacturer to trust for the most reliable, highest quality, longest lasting, affordable solutions on the market today.

Table of Contents

From terminals to transloaders and everything in between –
Those who know, call GREEN!

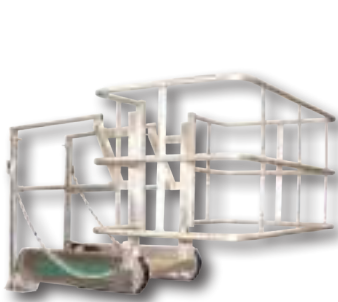

Gangway:
Flat Ramp
Pages 4-5



Gangway:
Telescoping Ramp
Pages 6-7



Gangway:
Self-Leveling Stairs
Pages 8-9

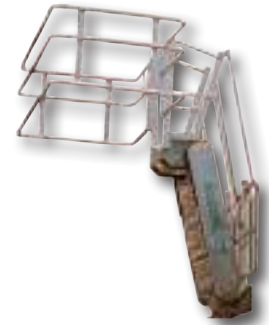

Gangway: 'Elite Series'
Self-Leveling Stairs
Pages 10-11

**Gangway: Safety Cages and
'Slide-Track' Mounts:** Pages 12-13



Railcar Access Platforms: Pages 14-15



Tank Truck Loading Racks: Pages 16-17

Manufactured by: **BENKO PRODUCTS**
ENGINEERED TO BE MORE

Benko Products Inc. · 5350 Evergreen Pkwy · Sheffield Village, Ohio · 44054
Phone (440) 934-2180 · Fax (440) 934-4052 · email: sales@benkoproducts.com
---- www.BenkoProducts.com ----



G-RAFF

G-Raff Elevating Platforms: Pages 18-19



Table of Contents



'Insta-Rack': Single Hatch
Pages 20-21



Mobile Platform /
Transloading Unit: Pgs. 22-23



Portable Platform / Ladder:
Pages 24-25



Custom Safety Systems:
Page 26



Horizontal Lifeline Systems:
Page 27



Loading Arms:
Page 28



Hose Handlers:
Page 29



Skid Systems:
Page 30



Spill Containment Pans:
Page 31



Custom Structural:
Page 32



Pipe Supports + Bridges:
Page 33



Flatbed Access Platforms:
Page 34

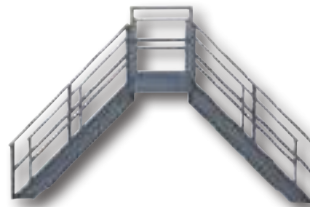

Accessories:
Page 35

BENKO PRODUCTS
ENGINEERED TO BE MORE

WARRANTY: All products manufactured by Benko Products, Inc. have a one (1) year warranty (unless otherwise specified) from the date of shipment against defects in workmanship or material. Any part or component, except items covered by warranties of other manufacturers, returned to the factory or service center freight prepaid by the owner, found upon examination by Benko Products, Inc. to be defective or the result of improper workmanship by the factory will be repaired or replaced without charge and returned to the owner freight prepaid by Benko Products, Inc. Any alterations of Benko Products, Inc. products void any warranty or liability on the part of Benko Products, Inc. Benko Products, Inc. does not guarantee product capacity if alterations are made.

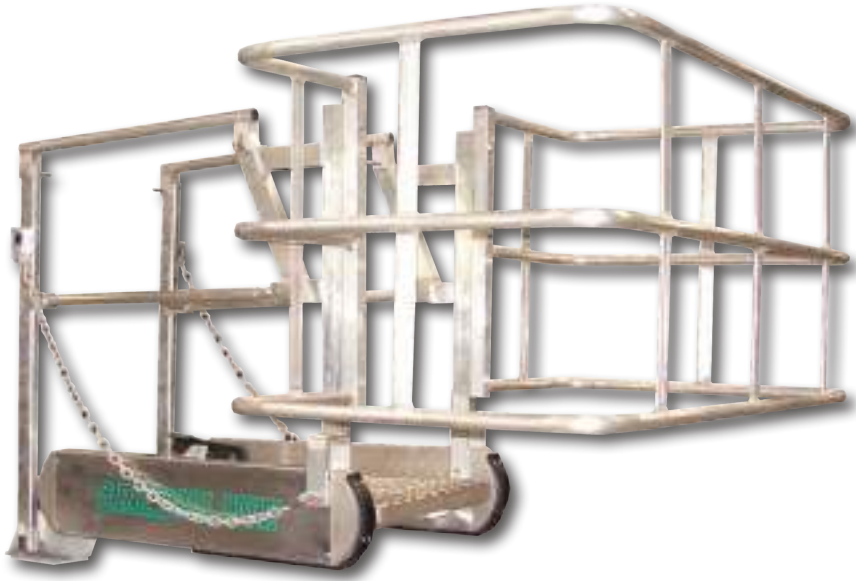

Gangway Model SB: Flat Ramp

GREENLINE Flat Ramp Gangways are specifically designed for various industries and applications that require accessing the top of a vehicle.

Most popular for accessing the tops of various Tank Truck trailers, our proven design is perfect for applications where the required range is within 15 degrees above or below the working platform height.

- **Cost Effective • Innovative Designs •**
- **Built-to-last! •**

Features

GREENLINE Flat Ramp Gangways have many unique features:

- More than 50 years in the field!
- **Spring counter-balanced for easy raising and lowering, manually!**
- Standard models up to 8' long or 6' wide. Custom dimensions also available upon request.
- Available with or without various safety cages, telescoping extensions, adjustable chain stops, and pull-up ropes
- Grip-strut tread standard
- Heavy-duty 1/2" bumpers protect vehicle from damage

Working Range

Working range is within 15 degrees above or below the platform height

--- See Range Chart on next page.

Safety Cages / Enclosures

- All gangway models available with or without a Safety Cage attached
- Standard Tank Truck and Railcar designs including 2, 3, or 4 rails
- Custom designed enclosures available to meet your specific application

Materials / Finishes

'Built-to-Last' rugged construction:

- Uncoated Aluminum or Carbon Steel models standard. All models include steel box-sections and back uprights
- Epoxy coated or hot dipped galvanized (steel)
- Galvanized steel adjustable chains
- Grip-strut tread standard. Fiberglass tread (FRP) also available
- Anodized coatings, Polyurethane paint systems, or customer supplied paint specifications accommodated.

Expedited Delivery Available

Contact your sales representative for more details and eligibility

Mounting / Installation

Simple, bolt-up assembly for quick and easy installations and replacements.

- Can be "side" or "top" mounted
- 'Slide-Track' rolling carriage systems available for horizontal tracking
- Pivot mounts for all models avail.

Engineering

Custom designed units are available to meet the most challenging applications

Options

- Larger models may require the use of a pneumatic or hydraulic lift packages
- Telescoping models also available (pages 6-7)

Manufactured by: **BENKO PRODUCTS**
ENGINEERED TO BE MORE

Benko Products Inc. · 5350 Evergreen Pkwy · Sheffield Village, Ohio · 44054
Phone (440) 934-2180 · Fax (440) 934-4052 · email: sales@benkoproducts.com

--- www.BenkoProducts.com ---



Gangway Model SB: Flat Ramp

Always confirm unit dimensions with your sales representative prior to ordering!



Newly redesigned box-sections and front uprights on all gangway models:

- Improve stability during use
- Reduce installation time
- Extend product life

Expedited Delivery Available!

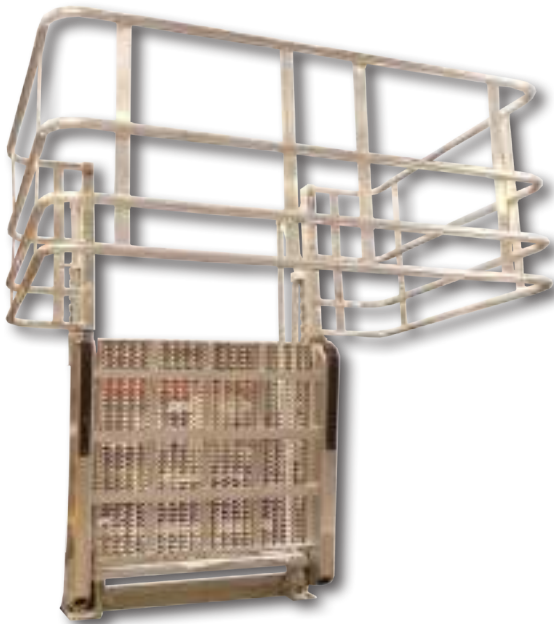
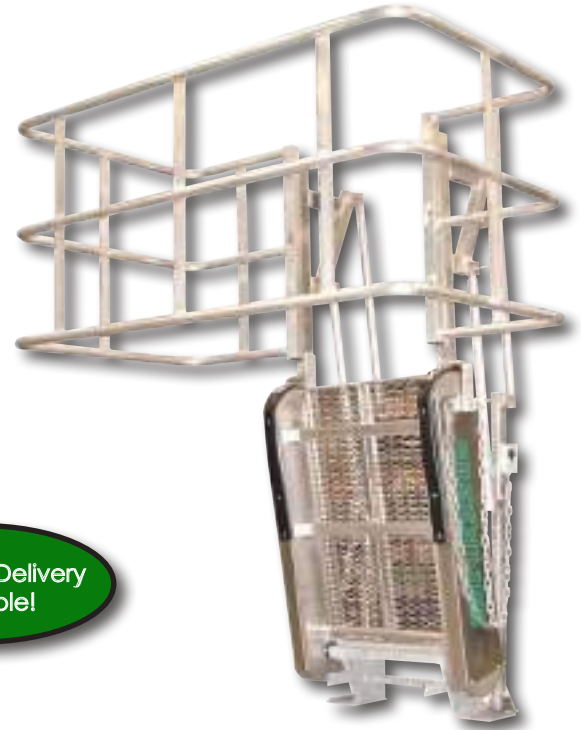

Standard models up to 8 feet long or 6 feet wide. Telescoping extensions, custom lengths, custom widths, and custom safety cages available.

Range when Side-Mounted

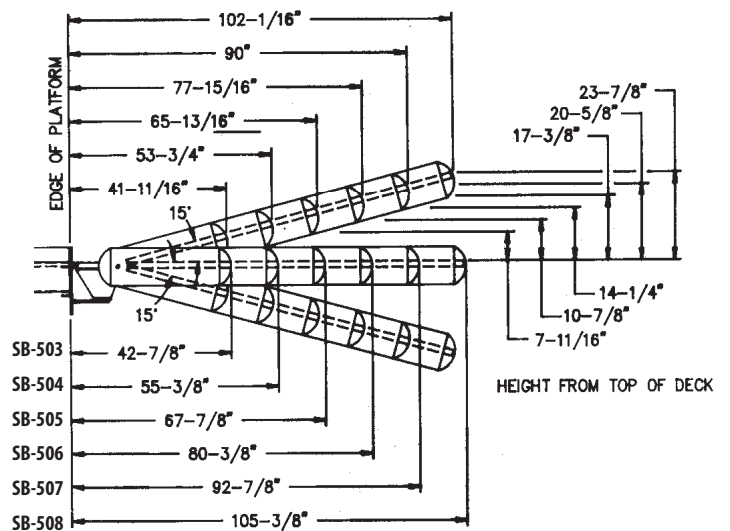

* (Aluminum model numbers shown. For steel, replace "SB-50#" with "SB-30#")

BENKO PRODUCTS
ENGINEERED TO BE MORE

WARRANTY: All products manufactured by Benko Products, Inc. have a one (1) year warranty (unless otherwise specified) from the date of shipment against defects in workmanship or material. Any part or component, except items covered by warranties of other manufacturers, returned to the factory or service center freight prepaid by the owner, found upon examination by Benko Products, Inc. to be defective or the result of improper workmanship by the factory will be repaired or replaced without charge and returned to the owner freight prepaid by Benko Products, Inc. Any alterations of Benko Products, Inc. products void any warranty or liability on the part of Benko Products, Inc. Benko Products, Inc. does not guarantee product capacity if alterations are made.



- **Cost Effective • Innovative Designs •**
- **Built-to-last! •**

Gangway Model SB-RT: Telescoping Ramp

The GREENLINE Telescoping Ramp Gangway Model SB-RT is a proven design with extended reach.

Perfect for Railcar applications or anywhere the working range is within 15 degrees above or below the platform height.

Features

GREENLINE Telescoping Ramp

Gangways have many unique features:

- Easy-to-use Telescoping extension for variable reaches
- **Spring counter-balanced for easy raising and lowering, manually!**
- Standard models up to 8' long or 5' wide. Custom dimensions also available upon request
- Available with various safety cages, adjustable chain stops, and pull-up ropes
- Grip-strut tread standard
- Heavy-duty 1/2" bumpers
- Expedited delivery available
- Optional pneumatic or hydraulic operation

Working Range

Working range is within 15 degrees above or below the platform height
--- **See Range Chart on next page.**

Safety Cages / Enclosures

- All gangway models available with or without a Safety Cage attached
- Standard Tank Truck and Railcar designs including 2, 3, or 4 rails
- Custom designed enclosures available to meet your specific application

Materials / Finishes

'Built-to-Last' rugged construction:

- Uncoated Aluminum or Carbon Steel models standard. All models include steel box-sections and back uprights
- Epoxy coated or hot dipped galvanized (steel)
- Galvanized steel adjustable chains
- Grip-strut tread standard. Fiberglass tread (FRP) also available
- Anodized coatings, Polyurethane paint systems, or customer supplied paint specifications accommodated.

Mounting / Installation

Simple, bolt-up assembly for quick and easy installations and replacements.

- Can be "side" or "top" mounted
- 'Slide-Track' rolling carriage systems available for horizontal tracking
- Pivot mounts for all models avail.

Engineering

Custom designed units are available. Contact us for more information on getting started today!



Manufactured by: **BENKO PRODUCTS**
ENGINEERED TO BE MORE

Benko Products Inc. · 5350 Evergreen Pkwy · Sheffield Village, Ohio · 44054
Phone (440) 934-2180 · Fax (440) 934-4052 · email: sales@benkoproducts.com
--- www.BenkoProducts.com ---



Gangway Model SB-RT: Telescoping Ramp

Always confirm unit dimensions with your sales representative prior to ordering!



Expedited Delivery Available!

Standard models up to 8' long or 5' wide.
Telescoping extensions, custom lengths, custom widths,
and custom safety cages available.



Newly redesigned box-sections and front uprights on all gangway models:

- Improve stability during use
- Reduce installation time
- Extend product life

Range when Side-Mounted

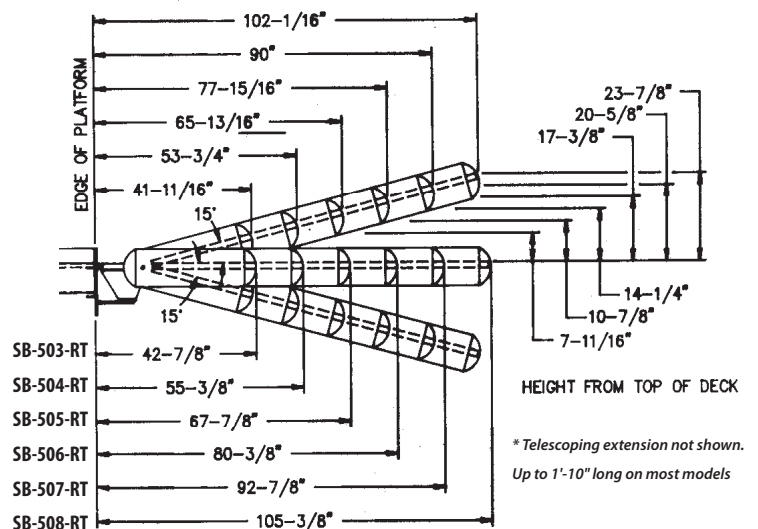

* (Aluminum model numbers shown. For steel, replace "SB-50#-RT" with "SB-30#-RT")

BENKO PRODUCTS
ENGINEERED TO BE MORE

WARRANTY: All products manufactured by Benko Products, Inc. have a one (1) year warranty (unless otherwise specified) from the date of shipment against defects in workmanship or material. Any part or component, except items covered by warranties of other manufacturers, returned to the factory or service center freight prepaid by the owner, found upon examination by Benko Products, Inc. to be defective or the result of improper workmanship by the factory will be repaired or replaced without charge and returned to the owner freight prepaid by Benko Products, Inc. Any alterations of Benko Products, Inc. products void any warranty or liability on the part of Benko Products, Inc. Benko Products, Inc. does not guarantee product capacity if alterations are made.



Gangway Model SS: Self-Leveling Stairs

GREENLINE Self-Leveling Stair Gangways are specifically designed for applications that require accessing the top of a vehicle more than 15 degrees above or below the working platform.

Available in various models to meet your application requirements.

- **Cost Effective • Innovative Designs •**
- **Built-to-last! •**

Features

GREENLINE Self-Leveling Stair

Gangways have many unique features:

- More than 50 years in the field!
- **Spring counter-balanced for easy raising and lowering, manually!**
- Standard models w/ up to 8 steps!
- Self-leveling, grip strut treads
- Available with or without various safety cages, adjustable chain stops and pull-up ropes
- Various options for customizing

Safety Cages / Enclosures

- Standard Tank Truck and Railcar designs, including 2, 3, or 4 rails
- Custom designed safety cages to meet your specific application

Working Range

Up to 45 degrees above or 40 degrees below the working platform.

--- See Range Chart on next page.

Materials / Finishes

'Built-to-last' rugged construction:

- Uncoated Aluminum or Carbon Steel models standard. All models include steel box-sections and back uprights
- Epoxy coated or hot dipped galvanized (steel)
- Galvanized steel adjustable chains
- Grip-strut tread standard. Fiberglass tread (FRP) also available
- Anodized coatings, Polyurethane paint systems or customer supplied paint specifications accommodated
- Oil-impregnated bronze flange bushings with individual treads

Mounting / Installation

Simple, bolt-up assembly for quick and easy installations and replacements:

- Can be 'side' or 'top' mounted
- 'Slide-Track' rolling carriage systems available for horizontal tracking
- Pivot mounts for all models avail.

Expedited Delivery Available

- Contact your sales representative for more details and eligibility

Engineering

Custom designed units are available to meet your specific application.



Newly redesigned box-sections and front uprights on all gangway models:

- **Improved stability during use**
- **Reduced installation time**
- **Extended product life**

Manufactured by: **BENKO PRODUCTS**
ENGINEERED TO BE MORE

Benko Products Inc. · 5350 Evergreen Pkwy · Sheffield Village, Ohio · 44054
Phone (440) 934-2180 · Fax (440) 934-4052 · email: sales@benkoproducts.com

--- www.BenkoProducts.com ---



Gangway Model SS: Self-Leveling Stairs

Always confirm unit dimensions with your sales representative prior to ordering!



Expedited Delivery Available!

**Standard models from 3 to 8 steps long.
Custom lengths, widths, and safety cages available.**

Range when Side Mounted

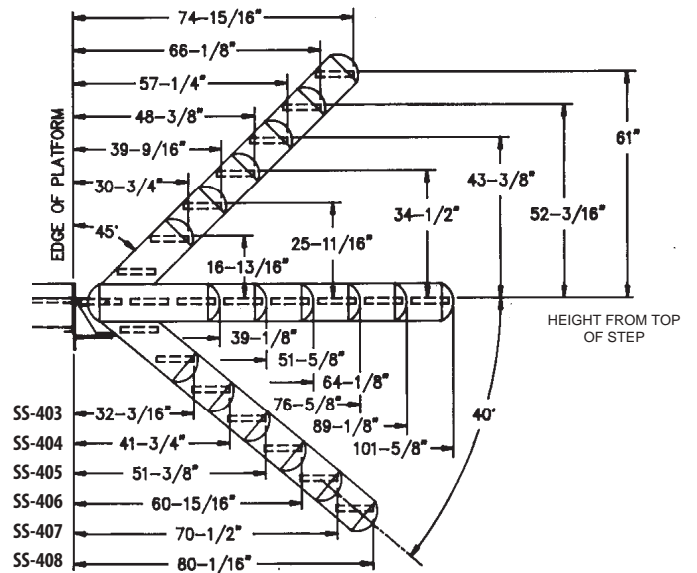
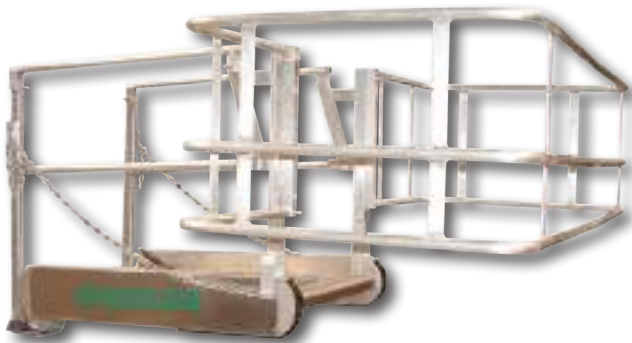

All GREENLINE Gangways available with adjustable chain stops and pull-up ropes.

* (Aluminum model numbers shown. For steel, replace "SS-40#" with "SS-20#")

BENKO PRODUCTS
ENGINEERED TO BE MORE

WARRANTY: All products manufactured by Benko Products, Inc. have a one (1) year warranty (unless otherwise specified) from the date of shipment against defects in workmanship or material. Any part or component, except items covered by warranties of other manufacturers, returned to the factory or service center freight prepaid by the owner, found upon examination by Benko Products, Inc. to be defective or the result of improper workmanship by the factory will be repaired or replaced without charge and returned to the owner freight prepaid by Benko Products, Inc. Any alterations of Benko Products, Inc. products void any warranty or liability on the part of Benko Products, Inc. Benko Products, Inc. does not guarantee product capacity if alterations are made.



Gangway 'Elite Series': Self-Leveling Stairs

GREENLINE 'Elite Series' Self-Leveling Stair Gangways deliver enhanced rigidity and an extended last step for safe access from a loading rack or dock to a tank vehicle or ISO-container.

The 'Elite Series' also offers larger handrails, galvanized steel back box-sections and back uprights on all models.

- **Cost Effective • Innovative Designs •**
- **Built-to-last! •**

Features

GREENLINE "Elite Series" Self-Leveling Stairs have many unique features:

- Ideal access for ISO-Containers
- **Spring counter-balanced for easy raising and lowering, manually!**
- Extended last step for better footing and working area for operator
- Available with or without various safety cages, adjustable chain stops and pull-up ropes
- Standard models from 3 to 8 steps
- Self-leveling, grip-strut treads
- Oil-impregnated bronze flange bushings with each tread
- Various options for customizing

Working Range

Up to 45 degrees above or 40 degrees below the working platform.

--- See Range Chart on page 9.

Safety Cages / Enclosures

- All gangway models available with or without a Safety Cage attached
- Standard Tank Truck and Railcar designs including 2, 3, or 4 rails
- Custom designed enclosures available to meet your specific application

Materials / Finishes

'Built-to-last' rugged construction:

- Uncoated Aluminum or Carbon Steel models standard. All models include steel box-sections and back uprights
- Epoxy coated or hot dipped galvanized (steel)
- Galvanized steel adjustable chains
- Grip-strut tread standard. Fiberglass tread (FRP) also available
- Anodized coatings, Polyurethane paint systems or customer supplied paint specifications accommodated
- Oil-impregnated bronze flange bushings, with individual treads

Mounting / Installation

Simple, bolt-up assembly for quick and easy installations and replacements:

- Can be 'side' or 'top' mounted
- 'Slide-Track' rolling carriage systems available for horizontal tracking
- Pivot mounts for all models avail.

Expedited Delivery Available

Contact your sales representative for more details and eligibility

Engineering

Custom designed units are available to meet the most challenging applications.

Options

- Larger models may require the use of a pneumatic or hydraulic lift package

Manufactured by: **BENKO PRODUCTS**
ENGINEERED TO BE MORE

Benko Products Inc. · 5350 Evergreen Pkwy · Sheffield Village, Ohio · 44054
Phone (440) 934-2180 · Fax (440) 934-4052 · email: sales@benkoproducts.com

--- www.BenkoProducts.com ---



Gangway 'Elite Series': Self-Leveling Stairs

Always confirm unit dimensions with your sales representative prior to ordering!

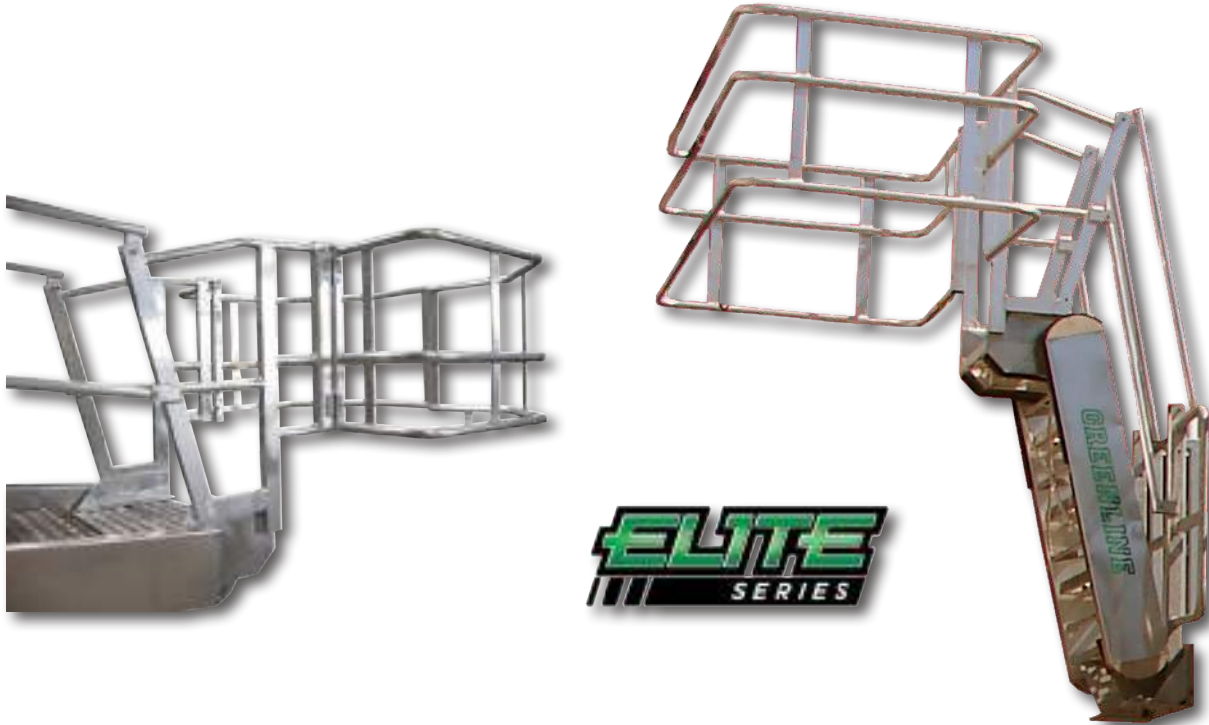

Custom lengths, widths, and safety cages available



Strong, stable connection points

BENKO PRODUCTS
ENGINEERED TO BE MORE

WARRANTY: All products manufactured by Benko Products, Inc. have a one (1) year warranty (unless otherwise specified) from the date of shipment against defects in workmanship or material. Any part or component, except items covered by warranties of other manufacturers, returned to the factory or service center freight prepaid by the owner, found upon examination by Benko Products, Inc. to be defective or the result of improper workmanship by the factory will be repaired or replaced without charge and returned to the owner freight prepaid by Benko Products, Inc. Any alterations of Benko Products, Inc. products void any warranty or liability on the part of Benko Products, Inc. Benko Products, Inc. does not guarantee product capacity if alterations are made.

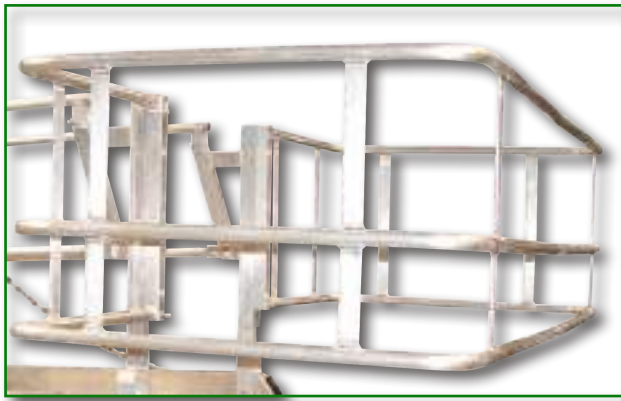

Tank Truck Standard: 4' deep x 6' wide, 3-rail Safety Cage

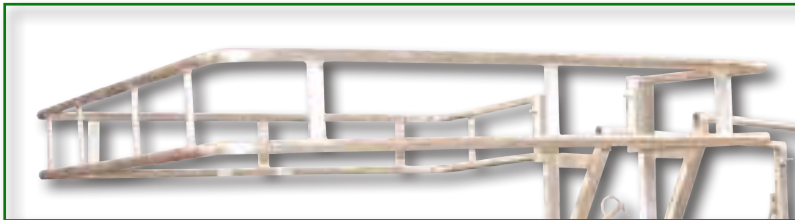

Railcar Standard 8' deep x 8' wide, 2-rail Safety Cage



Gangway Safety Cages

All GREENLINE Gangways are available with an attached, self-leveling **Safety Cage / Enclosure** to ensure maximum fall protection when working on the tops of tank trucks or railcars.

Easily customized to meet the most challenging applications, GREENLINE Safety Cages commonly come in 2-, 3-, or 4-rail designs.

Features

GREENLINE Safety Cages / Enclosures have many unique features:

- **Custom designed to meet your application!**
- Newly redesigned attachments provide stronger connections and stable operation
- Self-leveling or vertically stored
- Optional cut-outs or hinged openings



Tank Truck or Railcar

Standard design options include:

- 2-rail Railcar Safety Cages (12" high)
- 3-rail Tank Truck Safety Cages
- 4-rail Tank Truck Safety Cages
- Dimensions to meet your application

Finishes

- Uncoated aluminum (standard)
- Galvanized or painted steel
- Custom finishes available



Engineering

Custom designed units are available.

Our engineering team has over 150 years experience collectively and utilizes state-of-the-art CAD software to develop the solution your application requires.

Contact us for more information on getting started today!



Manufactured by: **BENKO PRODUCTS**
ENGINEERED TO BE MORE

Benko Products Inc. · 5350 Evergreen Pkwy · Sheffield Village, Ohio · 44054
Phone (440) 934-2180 · Fax (440) 934-4052 · email: sales@benkoproducts.com

---- www.BenkoProducts.com ----



'Slide-Track' Gangway Mounting

All GREENLINE Gangway models are available with a 'Slide-Track' mounting system designed for spotting flexibility and reaching multiple locations from a single platform.

Containing a rolling carriage, "winged" back uprights, and galvanized steel track for any distance required, 'Slide-track' mounting is a popular option in both Tank Truck and Railcar applications.

Features

The GREEN 'Slide-Track' Mounting system has many unique features:

- Eliminates the labor associated with miss-spotting, relocating, or uncoupling tank cars
- Self-closing swing gate access
- Swing-gate posts welded to track
- Tracks available in any length
- Simple bolt-up installs, new or retrofit

Materials of Construction

Rugged construction includes:

- Hot dip galvanized steel track
- Galvanized steel back uprights and "wings" for closing gaps
- Stainless steel ball bearing rollers

Tank Truck or Railcar

Perfect for flexible access in both Tank Truck and Railcar applications

Engineering

Custom designed systems are available.

Our engineering team has over 150 years experience collectively and utilizes state-of-the-art CAD software to develop the solution your application requires.

Contact us for more information on getting started today!

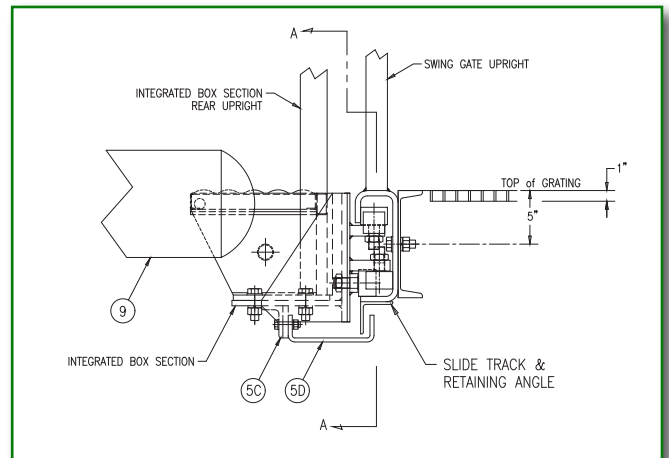
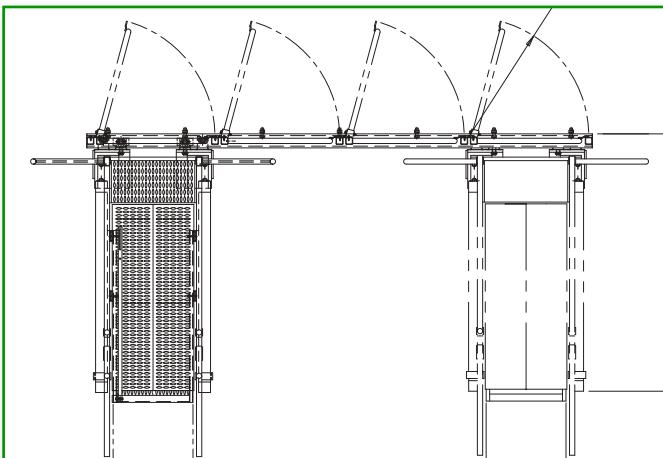

Manufactured by: **BENKO PRODUCTS**
ENGINEERED TO BE MORE

Benko Products Inc. · 5350 Evergreen Pkwy · Sheffield Village, Ohio · 44054
Phone (440) 934-2180 · Fax (440) 934-4052 · email: sales@benkoproducts.com
---- www.BenkoProducts.com ----



Railcar Loading Platforms

GREEN Railcar Loading Platforms have earned an industry reputation for heavy-duty modular construction and are designed with ease of installation in mind.

Available from 5 to 5,000 feet long, GREEN Railcar Access Platforms will meet the most challenging of applications and are built-to-last for decades of reliable service.



Features

GREEN Railcar Loading Platforms have many unique features:

- Each platform is custom designed to meet operational requirements
- Single or multiple hatch access
- Single-sided or double-sided
- Pedestal or chair supports
- With or without canopies
- Various integration options with loading arms, piping, skid systems, operator buildings and more



Access Equipment

Various access options include:

- Available with all gangway models
- 'Slide-track' or fixed mountings
- Custom designed safety cages or horizontal lifeline systems

Finishes

- Hot dipped galvanized
- Red oxide primer
- Gray enamel / Safety Yellow
- Custom finishes available



Engineering

Our engineering team has over 150 years experience collectively and utilizes state-of-the-art CAD software to develop the solution your application requires.

Contact your sales representative for more information today!

SEE ALSO: 'Insta-Rack' for Single-Hatch Access (Pgs. 20-21)



Manufactured by: **BENKO PRODUCTS**
ENGINEERED TO BE MORE

Benko Products Inc. · 5350 Evergreen Pkwy · Sheffield Village, Ohio · 44054
Phone (440) 934-2180 · Fax (440) 934-4052 · email: sales@benkoproducts.com
---- www.BenkoProducts.com ----



Railcar Loading Platforms

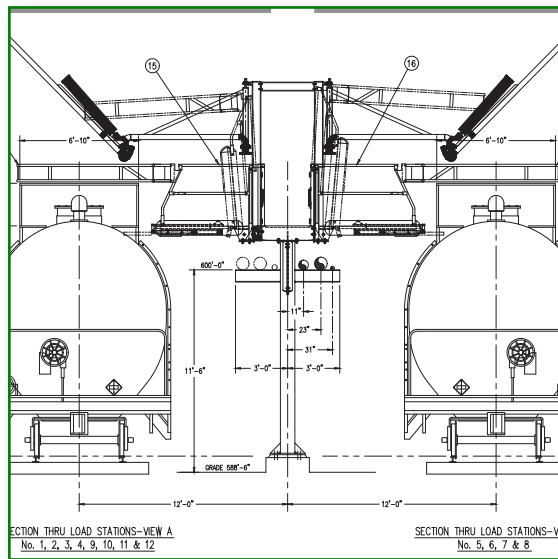

Contact us for more information on a custom solution for your application!

BENKO PRODUCTS
ENGINEERED TO BE MORE

WARRANTY: All products manufactured by Benko Products, Inc. have a one (1) year warranty (unless otherwise specified) from the date of shipment against defects in workmanship or material. Any part or component, except items covered by warranties of other manufacturers, returned to the factory or service center freight prepaid by the owner, found upon examination by Benko Products, Inc. to be defective or the result of improper workmanship by the factory will be repaired or replaced without charge and returned to the owner freight prepaid by Benko Products, Inc. Any alterations of Benko Products, Inc. products void any warranty or liability on the part of Benko Products, Inc. Benko Products, Inc. does not guarantee product capacity if alterations are made.



Truck Loading Racks

GREEN Truck Loading Racks have earned an industry reputation for heavy-duty modular construction and are designed with ease of installation in mind.

All GREEN Truck Loading Racks are engineered to meet the most challenging of applications and are built-to-last for decades of reliable service.

Features

GREEN Truck Loading Racks have many unique features:

- Each platform is custom designed to meet operational requirements
- Single or multiple hatch access
- Single-sided or double-sided
- With or without canopies
- Pedestal or chair supports
- Various integration options with loading arms, piping, skid systems, operator buildings and more



Access Equipment

Various access options include:

- Available with all gangway models
- 'Slide-track', fixed, or pivot mounting
- Custom designed safety cages or horizontal lifeline systems

Finishes

- Hot dipped galvanized
- Red oxide primer
- Gray enamel / safety yellow
- Custom finishes available



Engineering

Our engineering team has over 150 years experience collectively and utilizes state-of-the-art CAD software to develop the solution your application requires.

Contact your sales representative for more information today!

SEE ALSO: 'Insta-Rack' for easy-to-install Single-Hatch Access (Pgs. 20-21)



Manufactured by: **BENKO PRODUCTS**
ENGINEERED TO BE MORE

Benko Products Inc. · 5350 Evergreen Pkwy · Sheffield Village, Ohio · 44054
Phone (440) 934-2180 · Fax (440) 934-4052 · email: sales@benkoproducts.com
---- www.BenkoProducts.com ----



Tank Truck Loading Racks



Contact us for more information on a custom solution for your application!

BENKO PRODUCTS
 ENGINEERED TO BE MORE

WARRANTY: All products manufactured by Benko Products, Inc. have a one (1) year warranty (unless otherwise specified) from the date of shipment against defects in workmanship or material. Any part or component, except items covered by warranties of other manufacturers, returned to the factory or service center freight prepaid by the owner, found upon examination by Benko Products, Inc. to be defective or the result of improper workmanship by the factory will be repaired or replaced without charge and returned to the owner freight prepaid by Benko Products, Inc. Any alterations of Benko Products, Inc. products void any warranty or liability on the part of Benko Products, Inc. Benko Products, Inc. does not guarantee product capacity if alterations are made.

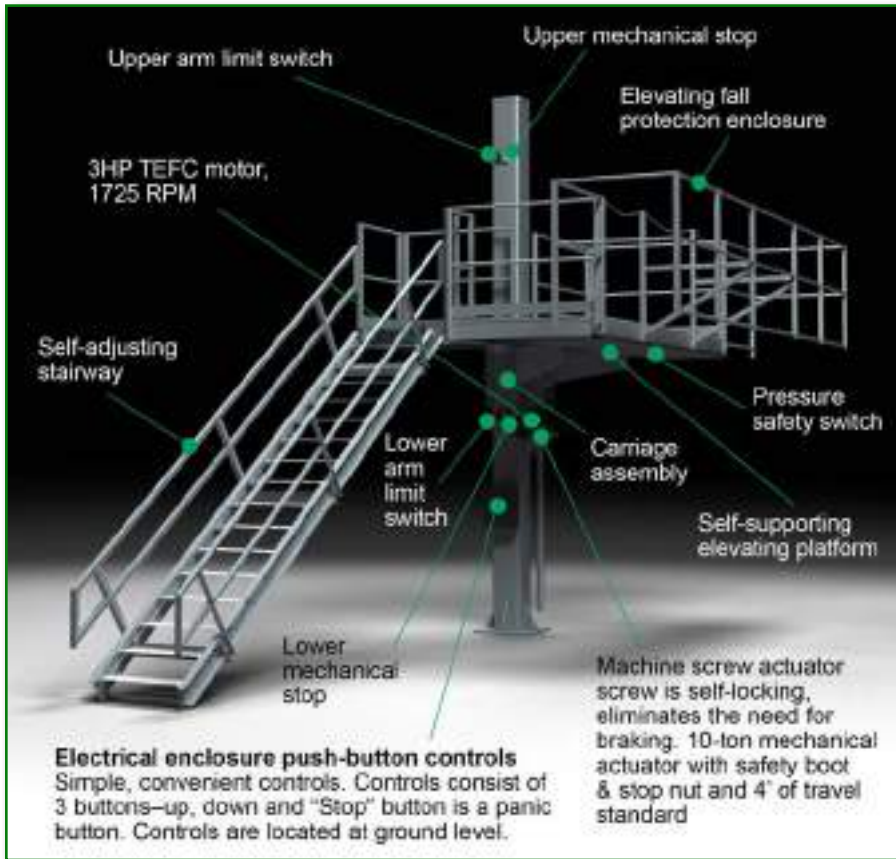

G-Raff Elevating Platform

The G-RAFF line of Elevating Platforms are the ultimate, patented, elevating platform specifically designed for tank/bulk trucks and rail cars.

Since 1983, G-Raff Elevating Platforms have been providing superior fall protection for all of the top ports on a typical tank/bulk truck or rail car.

Features

The G-Raff Elevating Platform has many unique features:

- Proven, patented design!
- Ideal for loading / unloading
- Available with various custom safety enclosures
- Self-supporting, level, elevating work platform and railing enclosure
- Machine screw actuation
- Push-button controls
- Able to support loading arms
- Rugged steel construction and top coated to your specifications
- Easy to install
- Operator friendly
- Can be custom designed to meet various applications
- Meets or exceeds OSHA requirements

Model M-5

Designed for tank / bulk trucks, Model M-5 provides fall protection for **single-top manholes**. Self-adjusting stairs give operators safe access to the top of the platform. Easily customized for your application.

Model M-26

Patented elevating platform specifically designed for **accessing multiple top ports** on a typical tank / bulk truck. Ideal for loading and easily customized.

HC and TR Series

The HC and TR series are patented elevating railing systems specifically designed for continuous fall protection on hopper cars (HC) or tank trucks (TR). Featuring a **self-supporting elevating railing enclosure**, machine screw actuation, and **stationary platform** with access stairway.

RTT Series

The RTT series is designed to provide safe access and fall protection like the M-26 and does not require self-leveling stairs. The RTT is **retrofitted to existing truck loading platforms**, making it ideal for replacing manual gangways. Models range from protecting a single manhole to the entire length of the truck.

Engineering

Custom engineered units are available. Contact us for more information on getting started today!



Manufactured by: **BENKO PRODUCTS**
ENGINEERED TO BE MORE

Benko Products Inc. · 5350 Evergreen Pkwy · Sheffield Village, Ohio · 44054
Phone (440) 934-2180 · Fax (440) 934-4052 · email: sales@benkoproducts.com
---- www.BenkoProducts.com ----



G-Raff Elevating Platform

Always confirm unit dimensions with your sales representative prior to ordering!



Contact us for more information on a custom solution for your application!

BENKO PRODUCTS
ENGINEERED TO BE MORE

WARRANTY: All products manufactured by Benko Products, Inc. have a one (1) year warranty (unless otherwise specified) from the date of shipment against defects in workmanship or material. Any part or component, except items covered by warranties of other manufacturers, returned to the factory or service center freight prepaid by the owner, found upon examination by Benko Products, Inc. to be defective or the result of improper workmanship by the factory will be repaired or replaced without charge and returned to the owner freight prepaid by Benko Products, Inc. Any alterations of Benko Products, Inc. products void any warranty or liability on the part of Benko Products, Inc. Benko Products, Inc. does not guarantee product capacity if alterations are made.



'Insta-Rack' Pedestal Platform

GREEN Insta-Rack Pedestal Platforms provide safe access and fall protection to the tops of single-dome tank / bulk trucks, tank cars and hopper cars.

All Insta-Racks come equipped with a single pedestal platform, access stairway and access equipment. A four-column support design is also available with integrated loading arm support.

Features

GREEN 'Insta-Rack' Pedestal Platforms have many unique features:

- Standard designs for Railcar and Tank Truck applications
- Quick and easy assembly
- Single or double-sided access
- May be equipped with static, pivot, or 'Slide-track' mounting
- Various integration options with loading arms, piping, skid systems, and more



Access Equipment

Various access options include:

- All gangway models
- 'Slide-track', pivot, or fixed mounting
- Custom designed safety cages or horizontal lifeline systems

Materials / Finishes

- Galvanized steel standard
- Aluminum available
- Red oxide primer
- Gray / Yellow enamel or Custom



'Removable Insta-Rack'

For situations requiring more flexibility, our 'Removable Insta-Rack' features a counter-weighted base design, eliminating the need for a permanent foundation. Ask your sales representative for more information.

Engineering

Custom designed units are available. Contact us for more information on getting started today!



Manufactured by: **BENKO PRODUCTS**
ENGINEERED TO BE MORE

Benko Products Inc. · 5350 Evergreen Pkwy · Sheffield Village, Ohio · 44054
Phone (440) 934-2180 · Fax (440) 934-4052 · email: sales@benkoproducts.com

---- www.BenkoProducts.com ----



'Insta-Rack' Pedestal Platform

Always confirm unit dimensions with your sales representative prior to ordering!

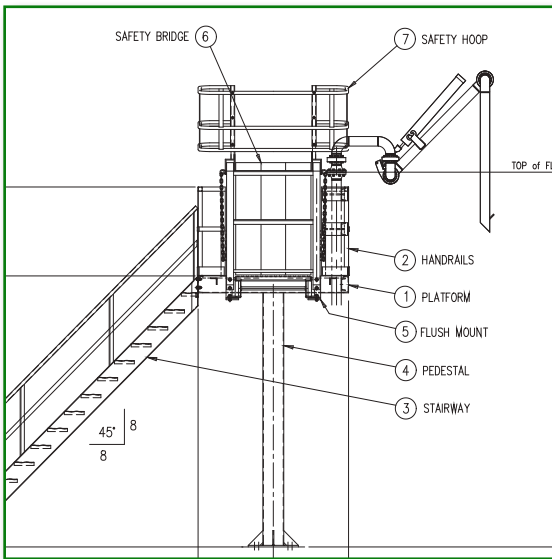

Contact us for more information on a custom solution for your application!

BENKO PRODUCTS
ENGINEERED TO BE MORE

WARRANTY: All products manufactured by Benko Products, Inc. have a one (1) year warranty (unless otherwise specified) from the date of shipment against defects in workmanship or material. Any part or component, except items covered by warranties of other manufacturers, returned to the factory or service center freight prepaid by the owner, found upon examination by Benko Products, Inc. to be defective or the result of improper workmanship by the factory will be repaired or replaced without charge and returned to the owner freight prepaid by Benko Products, Inc. Any alterations of Benko Products, Inc. products void any warranty or liability on the part of Benko Products, Inc. Benko Products, Inc. does not guarantee product capacity if alterations are made.



Portable Transloading Platform

GREEN Portable Transloading Platforms provide a mobile access solution for transloading operations, either "Truck to Rail," or "Rail to Truck."

All GREEN platforms are engineered for operator safety, compliance with governing O.S.H.A. standards, and for your specific application.

Features

GREEN Portable Transloading Platforms have many unique features:

- Custom designed to meet your application!
- May be equipped with several access options
- Various integration options with transloading systems
- Rolling base design for different site and operational requirements



Access

- Platform and stairs with O.S.H.A. compliant handrail, midrail, and toe-board
- Available in Single or Double configurations
- Available with all model Gangways and Safety Cages / Enclosures
- Safety enclosures are standard on access equipment for operator safety while on top of trucks and railcars

Materials / Finishes

- Galvanized steel standard
- Aluminum available
- Gray / Yellow enamel or Custom

Engineering

GREEN designs and custom-builds portable transloading systems that meet even the most challenging requirements.

Our engineering team has over 150 years experience collectively and utilizes state-of-the-art CAD software.

Options

- Trailer package
- Loading arms
- Hose handlers
- Pump and metering systems
- Operator buildings

Contact us for more information on a custom solution for your application!



Manufactured by: **BENKO PRODUCTS**
ENGINEERED TO BE MORE

Benko Products Inc. · 5350 Evergreen Pkwy · Sheffield Village, Ohio · 44054
Phone (440) 934-2180 · Fax (440) 934-4052 · email: sales@benkoproducts.com
---- www.BenkoProducts.com ----



Portable Transloading Platform

Always confirm unit dimensions with your sales representative prior to ordering!



Contact us for more information on a custom solution for your application!

BENKO PRODUCTS
ENGINEERED TO BE MORE

WARRANTY: All products manufactured by Benko Products, Inc. have a one (1) year warranty (unless otherwise specified) from the date of shipment against defects in workmanship or material. Any part or component, except items covered by warranties of other manufacturers, returned to the factory or service center freight prepaid by the owner, found upon examination by Benko Products, Inc. to be defective or the result of improper workmanship by the factory will be repaired or replaced without charge and returned to the owner freight prepaid by Benko Products, Inc. Any alterations of Benko Products, Inc. products void any warranty or liability on the part of Benko Products, Inc. Benko Products, Inc. does not guarantee product capacity if alterations are made.



Portable Platform PAL-100

The GREEN Portable Platform, PAL-100, is designed to provide safe access and fall protection on the tops of tank and bulk trucks.

This self-supporting unit provides portable access with a safety cage designed for applications that do not allow the ability to use permanent truck loading platforms, or when space is limited.



Features

GREEN Portable Platforms have many unique features:

- Adjustable height from 9' to 13'
- Self-supporting design.
- Work platform 2' x 4' long, with grip strut surface
- Rubber bumpers to prevent direct contact with the vehicle
- Ergonomically designed, manual cable operation
- Outriggers are adjustable and designed to be used at all heights

Materials of Construction

Rugged construction includes:

- Welded steel frame with aluminum safety cages
- 2, 10" swivel casters with brakes (steel with mold-on rubber)
- 2, 10" fixed direction casters (steel with mold-on rubber)

Finish

- Hot dipped galvanized
- Gray enamel / Safety Yellow
- Custom finishes available

Self-Supporting Design

- Counterweighted design allows access without being supported by the vehicle.
- Rated to 500 lbs.

Safety Cages

- Standard Tank Truck and Railcar designs available
- Custom designed safety cages to meet your specific application

Engineering

Custom designed units are available. Contact us for more information on getting started today!

Options

- 10" foam filled tires available for use on rough terrain such as gravel or asphalt
- Optional tow-bar for pulling unit around facility - removable
- Optional self-closing swing gates at either end of platform for increased operator fall prevention



Manufactured by: **BENKO PRODUCTS**
ENGINEERED TO BE MORE

Benko Products Inc. · 5350 Evergreen Pkwy · Sheffield Village, Ohio · 44054
Phone (440) 934-2180 · Fax (440) 934-4052 · email: sales@benkoproducts.com
---- www.BenkoProducts.com ----



Portable Platform: PAL-100

Always confirm unit dimensions with your sales representative prior to ordering!

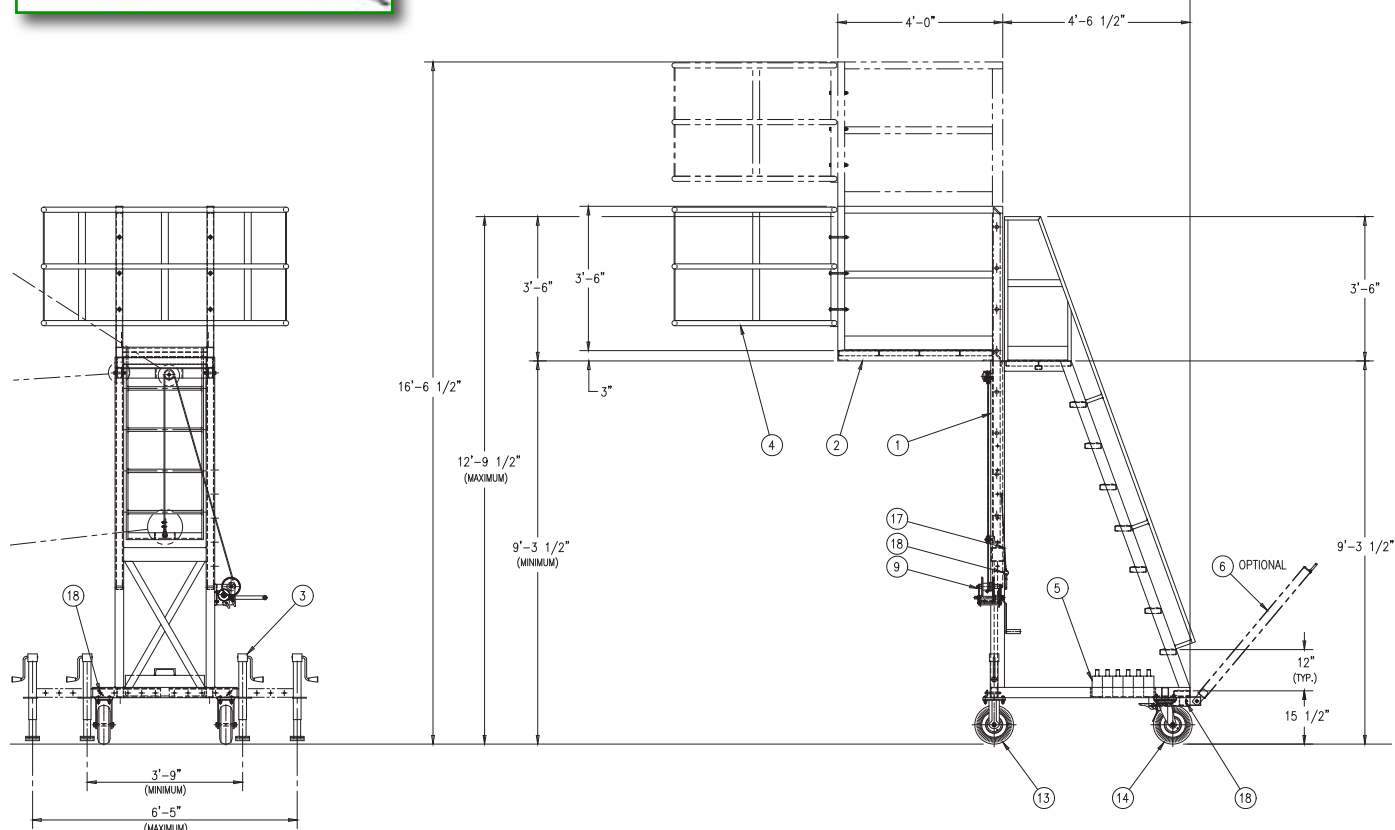
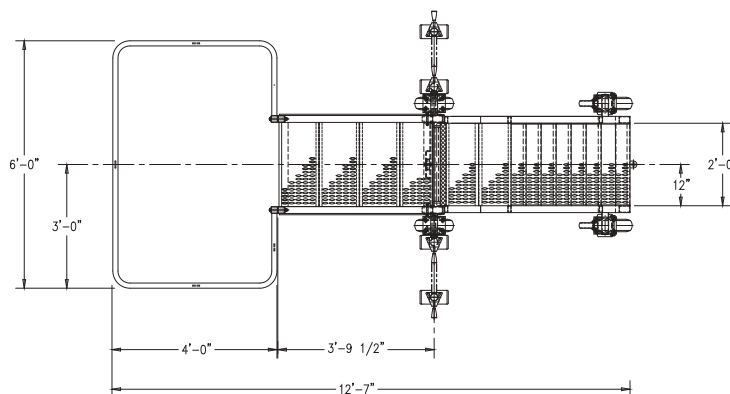

Contact us for more information on a custom solution for your application!

BENKO PRODUCTS
ENGINEERED TO BE MORE

WARRANTY: All products manufactured by Benko Products, Inc. have a one (1) year warranty (unless otherwise specified) from the date of shipment against defects in workmanship or material. Any part or component, except items covered by warranties of other manufacturers, returned to the factory or service center freight prepaid by the owner, found upon examination by Benko Products, Inc. to be defective or the result of improper workmanship by the factory will be repaired or replaced without charge and returned to the owner freight prepaid by Benko Products, Inc. Any alterations of Benko Products, Inc. products void any warranty or liability on the part of Benko Products, Inc. Benko Products, Inc. does not guarantee product capacity if alterations are made.



Custom Safety Systems

GREEN Custom Safety Systems are designed to provide safe access and fall protection to tank / bulk trucks, tank cars, and hopper cars.

All GREEN custom safety systems are engineered for operator safety, for compliance with governing O.S.H.A. standards as we interpret them, and for your specific application.

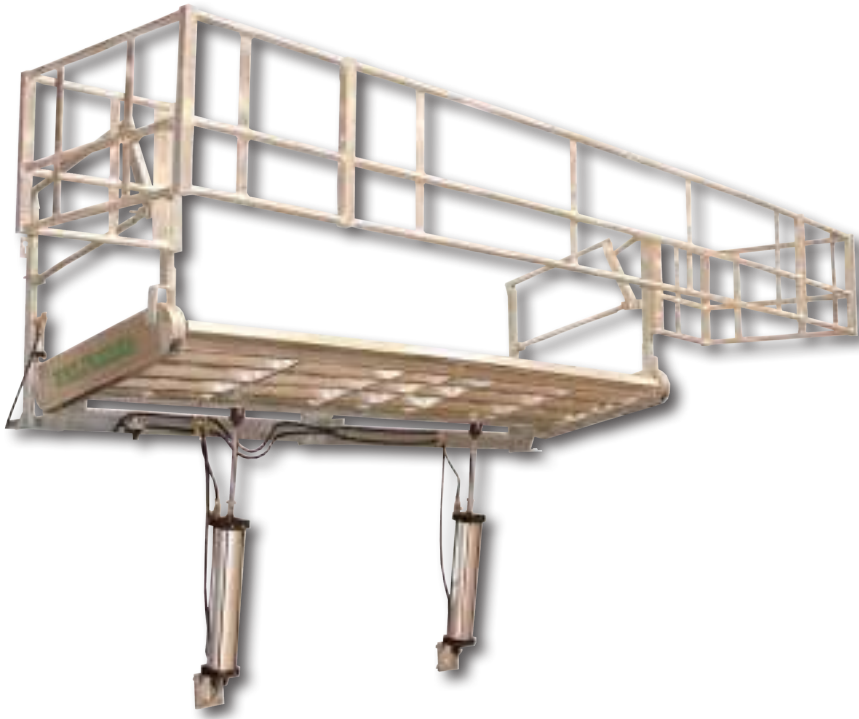

Features

GREEN Custom Safety Systems have many unique features:

- Custom designed lengths anywhere from 5' to 40'
- Self-leveling safety enclosures surround the operator for superior fall protection with less space restrictions than standard gangways
- Meets and/or exceeds O.S.H.A. requirements



Access Designs

- Flat ramp or telescoping bridges
- Self-leveling stair treads
- Optional articulating safety cages
- Optional pneumatic / hydraulic lift operation

Materials / Finishes

- Uncoated Aluminum or Painted
- Hot dipped galvanized steel
- Gray / Yellow enamel or Custom



Engineering

GREEN designs and custom builds safety systems that meet even the most challenging requirements.

Our engineering team has over 150 years experience collectively and utilizes state-of-the-art CAD software.

Contact us for more information on a custom solution for your application!

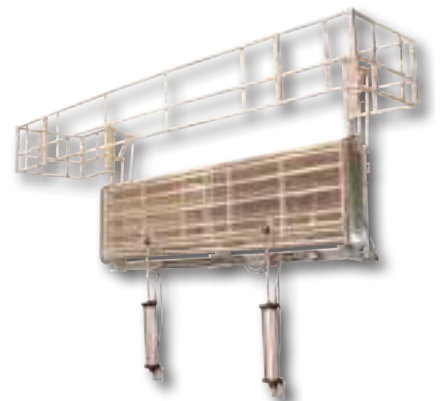

Manufactured by: **BENKO PRODUCTS**
ENGINEERED TO BE MORE

Benko Products Inc. · 5350 Evergreen Pkwy · Sheffield Village, Ohio · 44054
Phone (440) 934-2180 · Fax (440) 934-4052 · email: sales@benkoproducts.com
---- www.BenkoProducts.com ----



Horizontal Lifeline Systems

GREEN Horizontal Lifeline Systems are permanently installed, multi-span, horizontal lifelines designed to provide safe access and continuous fall protection to any operator requiring horizontal mobility.

All GREEN lifeline systems are engineered for operator safety and compliance with governing O.S.H.A. standards specific to your application.



Features

GREEN Horizontal Lifeline Systems have many unique features:

- Custom designed for single or multiple access points
- Beam, truss, and cable systems available
- Includes our "Insta-Rack" pedestal platform for easy access to the tops of vehicles
- Meets and/or exceeds O.S.H.A. requirements for fall protection



Access

Various access options include:

- A range of man-rated trolleys can be run along overhead beams, trusses, or cables for continuous fall protection
- Various platforms and gangways

Finishes

- Hot dipped galvanized
- Gray enamel / Safety Yellow
- Custom finishes available



Engineering

GREEN designs and custom-builds horizontal lifeline systems that meet even the most challenging requirements.

Our engineering team has over 150 years experience collectively and utilizes state-of-the-art CAD software.

Contact us for more information on a custom solution for your application!



Manufactured by: **BENKO PRODUCTS**
ENGINEERED TO BE MORE

Benko Products Inc. · 5350 Evergreen Pkwy · Sheffield Village, Ohio · 44054
Phone (440) 934-2180 · Fax (440) 934-4052 · email: sales@benkoproducts.com
---- www.BenkoProducts.com ----



Loading Arms

GREEN offers a complete line of **Loading Arms and Accessories** for bulk chemical loading operations in both Tank Truck and Railcar applications.

All GREEN loading arms are engineered for operator safety, ease of operation, and for your specific application.

Quality construction, timely delivery, and start-to-finish customer support are just some of the reasons to make GREEN your only source for all your Loading Arms needs.

Features

GREEN offers Loading Arms that have many unique features:

- Complete line of Loading Arms and accessories for both Tank Truck and Railcar applications
- Spring-canister balanced models
- Design integration into any new or existing loading rack / platform
- Top and bottom loading arms
- Available loading arm supports built into the platform



Railcar Loading Arms

- Top or bottom models, loading or unloading
- Supported or unsupported boom arms, fixed or variable reach
- Bullhorn, vapor, and bypass arms among the various options

Truck Loading Arms

- Top or bottom, loading or unloading
- Supported or unsupported boom arms, fixed or variable reach



Engineering

Custom designed bulk fluid transfer systems are available to meet the most challenging operational requirements.

Our engineering team has over 150 years experience collectively and utilizes state-of-the-art CAD software.

Contact us for more information on a custom solution for your application!



BENKO PRODUCTS
ENGINEERED TO BE MORE

Benko Products Inc. · 5350 Evergreen Pkwy · Sheffield Village, Ohio · 44054
Phone (440) 934-2180 · Fax (440) 934-4052 · email: sales@benkoproducts.com

---- www.BenkoProducts.com ----



Hose Handler Hose Support Arm

The GREEN Hose Handler / Support Arm is designed to make the liquid transfer loading and unloading process with flexible hoses easier and more ergonomic for operators.

Eliminate tripping hazards, reduce processing time, and keep your platforms organized with a custom designed GREEN Hose Support Arm / Boom Arm.

Features

GREEN Hose Handlers / Support Arms have many unique features:

- Designed to meet your application
- Up to 12' adjustable reach
- Can be retrofit to existing platforms or incorporated into new designs
- Easy-to-operate winch and swivels
- Stores in the folded position
- Available safety stops
- Ratings up to 300 lbs.
- 1-year Manufacturer's warranty.

Materials of Construction

Rugged construction includes:

- Welded carbon steel
- 1500 lb. rated brake winch
- 3/16" wire rope

Finishes

- Hot dipped galvanized
- Gray enamel / Safety Yellow
- Custom finishes available

Applications

- Oil and Gas Industry
- Petrochemical and Chemical Industry
- Pharmaceutical Industry
- Food and Beverage Industry
- Special Applications

Platform Integration

- Can be combined with any new GREEN platform / loading rack and gangway configuration
- Available retrofit designs for various mounting requirements

Engineering

Custom engineered, computer designed units are available.

Contact us for more information on getting started today!

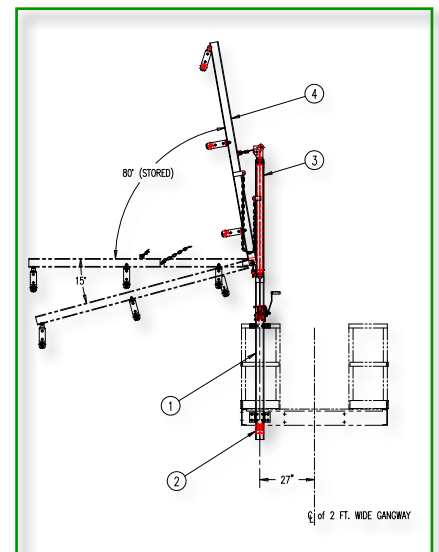

Manufactured by: **BENKO PRODUCTS**
ENGINEERED TO BE MORE

Benko Products Inc. · 5350 Evergreen Pkwy · Sheffield Village, Ohio · 44054
Phone (440) 934-2180 · Fax (440) 934-4052 · email: sales@benkoproducts.com
---- www.BenkoProducts.com ----



Skid Systems

GREEN offers a complete line of **Skid Systems** and accessories for bulk chemical loading and unloading operations.

Quality construction, timely delivery, and start-to-finish customer support are just some of the reasons to make GREEN the only source for all your Skid System needs.



Features

GREEN offers Skid Systems that have many unique features:

- Custom designed for your application
- Loading or unloading, top or bottom
- Full metering and documentation available
- Single stream or in-line blending
- Optional loading arms
- Over-flow protection options
- RIN specifications



Uses

- Gasoline
- Diesel
- Methanol
- Transloading
- Asphalt
- Sulfuric Acid
- Specialty chemicals
- Biodiesel load out and blending
- Ethanol load out and blending
- Glycerine load out
- More...



Engineering

GREEN designs and custom builds bulk liquid transfer facilities that meet even the most challenging requirements.

Our engineering team has over 150 years experience collectively and utilizes state-of-the-art CAD software.

Contact us for more information on a custom solution for your application!



Manufactured by: **BENKO PRODUCTS**
ENGINEERED TO BE MORE

Benko Products Inc. · 5350 Evergreen Pkwy · Sheffield Village, Ohio · 44054
Phone (440) 934-2180 · Fax (440) 934-4052 · email: sales@benkoproducts.com

---- www.BenkoProducts.com ----



Spill Containment Pans

GREEN offers **Spill Containment Pans** that help keep railcar and tank truck loading areas clean by containing incidental spills that occur during liquid transfer operations.

Used individually or strung together, our spill containment pans are easily installed, and can be customized in length.

Features

GREEN offers **Spill Containment Pans** that have many unique features:

- Pans may be placed end-to-end for continuous coverage
- Can be customized in length
- Effective in both permanent and portable applications
- Usable in hot or cold climates
- Non-porous design
- Can be plumbed to a remote holding tank to provide for collection of large capacity spills
- Available with outrigger pans for spill containment on both sides of the track
- Meets and / or exceeds local, state, and federal regulations

Materials / Finishes

Available in:

- High-density Polyethelene
- Painted Steel
- Galvanized Steel

Installation

A fast, clean installation includes:

- Limited site preparation
- No excavation
- No removal or modification to your current track required
- Ready for immediate use
- Can also be plumbed to a remote holding tank



Engineering

Our engineering team has over 150 years experience collectively and utilizes state-of-the-art CAD software.

Contact us for more information on a custom solution for your application!



Manufactured by: **BENKO PRODUCTS**
ENGINEERED TO BE MORE

Benko Products Inc. · 5350 Evergreen Pkwy · Sheffield Village, Ohio · 44054
Phone (440) 934-2180 · Fax (440) 934-4052 · email: sales@benkoproducts.com
---- www.BenkoProducts.com ----



Custom Structural Fabrication

GREEN designs and custom-builds Custom Structural Fabrications to meet the needs of any application.

GREEN is a one-stop source for all your Custom Structural project needs. Our years of experience in design and fabrication ensure that your project will install and function smoothly, start to finish.

Features

GREEN Custom Structural Fabrications are available in any arrangement necessary and have served many industries, including:

- Chemical / Processing
- Marine
- Utilities
- Refining
- Military / Government
- Oil, Gas, Petroleum.
- Many more...



Materials

Material choices include:

- Carbon steel
- Aluminum
- Stainless steel

Finishes

- Hot-dipped galvanized
- Red oxide primer
- Gray enamel/ Safety Yellow
- Custom finishes available



Engineering

GREEN designs and custom-builds structural fabrications that meet even the most challenging requirements.

Our engineering team has over 150 years experience collectively and utilizes state-of-the-art CAD software.

Contact us for more information on a custom solution for your application!



Manufactured by: **BENKO PRODUCTS**
ENGINEERED TO BE MORE

Benko Products Inc. · 5350 Evergreen Pkwy · Sheffield Village, Ohio · 44054
Phone (440) 934-2180 · Fax (440) 934-4052 · email: sales@benkoproducts.com
---- www.BenkoProducts.com ----



Pipe Racks and Supports

GREEN designs and custom builds **Pipe Racks and Supports** to meet the needs of any application.

GREEN is a one-stop source for all your Pipe Rack needs. Our years of experience in design and fabrication ensure that your project will install and function smoothly, start to finish.

Features

GREEN Pipe Racks and Supports are available in any rise / run required and have served many industries, including:

- Transportation
- Chemical / Processing
- Marine
- Utilities
- Refining
- Military / Government
- Oil, Gas, Petroleum.
- Many more...



Materials

Material choices include:

- Carbon steel
- Aluminum
- Stainless steel

Finishes

- Hot-dipped galvanized
- Red oxide primer
- Gray enamel/ Safety Yellow
- Custom finishes available



Engineering

GREEN designs and custom builds pipe-support systems that meet even the most challenging requirements.

Our engineering team has over 150 years experience collectively and utilizes state-of-the-art CAD software.

Contact us for more information on a custom solution for your application!



Manufactured by: **BENKO PRODUCTS**
ENGINEERED TO BE MORE

Benko Products Inc. · 5350 Evergreen Pkwy · Sheffield Village, Ohio · 44054
Phone (440) 934-2180 · Fax (440) 934-4052 · email: sales@benkoproducts.com
---- www.BenkoProducts.com ----



Flatbed Access Platforms

GREEN Flatbed Access Platforms offer superior fall protection when gaining access to flatbed trailers for tarping or securing loads.

Built to customer specifications and fully customized, our Flatbed Access Platforms are the perfect solution for preventing falls for those climbing on flatbed trailers, a notoriously dangerous and common situation.



Features

GREEN Flatbed Access Platforms have many unique features:

- Built to customer specifications
- Roll-track design allows for varying trailer widths and easier trailer placement
- Increase productivity and facility safety at the same time
- Lightweight aluminum construction



Access Equipment

- These rolling platforms can also be combined with double-access platforms for greater site flexibility and extended access options
- Available with Self-Closing Swing Gate access

Finishes

- Aluminum
- Gray enamel / Safety Yellow
- Custom finishes available

Engineering

GREEN designs and custom-builds fall protection systems that meet even the most challenging requirements.

Our engineering team has over 150 years experience collectively and utilizes state-of-the-art CAD software.

Options

- Custom dimensions and orientations available
- Available powered operation for use by a single person

Contact us for more information on a custom solution for your application!



Manufactured by: **BENKO PRODUCTS**
ENGINEERED TO BE MORE

Benko Products Inc. · 5350 Evergreen Pkwy · Sheffield Village, Ohio · 44054
Phone (440) 934-2180 · Fax (440) 934-4052 · email: sales@benkoproducts.com
---- www.BenkoProducts.com ----



Accessories & Related Products

GREEN offers a variety of accessories and related products to help cover situations typical to the industry, including: pipe and dike bridges, caged ladders, pipe supports, skid systems and loading arm structural supports, self-closing swing gates and more!

Cross-Overs / Pipe or Dike Bridges

GREEN Pipe and Dike Bridges can be customized to meet any rise and run required. Available in steel or aluminum, with various custom finishes. Contact your sales representative for more information!

Mezzanine Safety Gates

Benko Products also manufactures a complete line of industrial safety gates:

- The **Clear-Aisle Safety Gate** uses only 10 inches of floor space
- **Pivot Safety Gates (Patented)**
- **Loading Dock Gates**

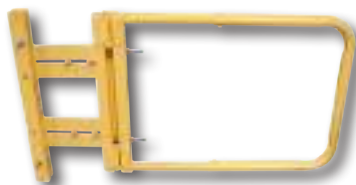

Self-Closing Swing Gates

Versatile, adjustable swing gates for fall protection:

- For guarding ladder openings, stairwells, gangway openings, or portable platform ledges.
- 3 standard sizes for openings up to 48" wide
- Rugged steel or aluminum construction



Caged Ladders

GREEN has a complete line of caged ladders available. Built per customer's specifications and available in various materials and finishes.

Please contact your sales representative for more information!

Also by Benko Products, Inc.

For more information on all of the product lines manufactured by Benko Products, please visit www.BenkoProducts.com.



Other product offerings include:

- **The Sahara 'Hot Box' Drum and Tote Warming Ovens (pictured)**
- **Sahara Industrial Ovens: Batch, Conveyor, Cabinet and more**
- **EPI Chemical Storage Buildings and Containers**
- **Husky Industrial Refrigerators and Cold Storage Buildings**
- **Protect-O-Gate Industrial and Mezzanine Safety Gates**

Manufactured by: **BENKO PRODUCTS**
ENGINEERED TO BE MORE

Benko Products Inc. · 5350 Evergreen Pkwy · Sheffield Village, Ohio · 44054
Phone (440) 934-2180 · Fax (440) 934-4052 · email: sales@benkoproducts.com
---- www.BenkoProducts.com ----

From Terminals to Transloaders and everything in between... Those who know, call GREEN!



GREEN Access & Fall Protection

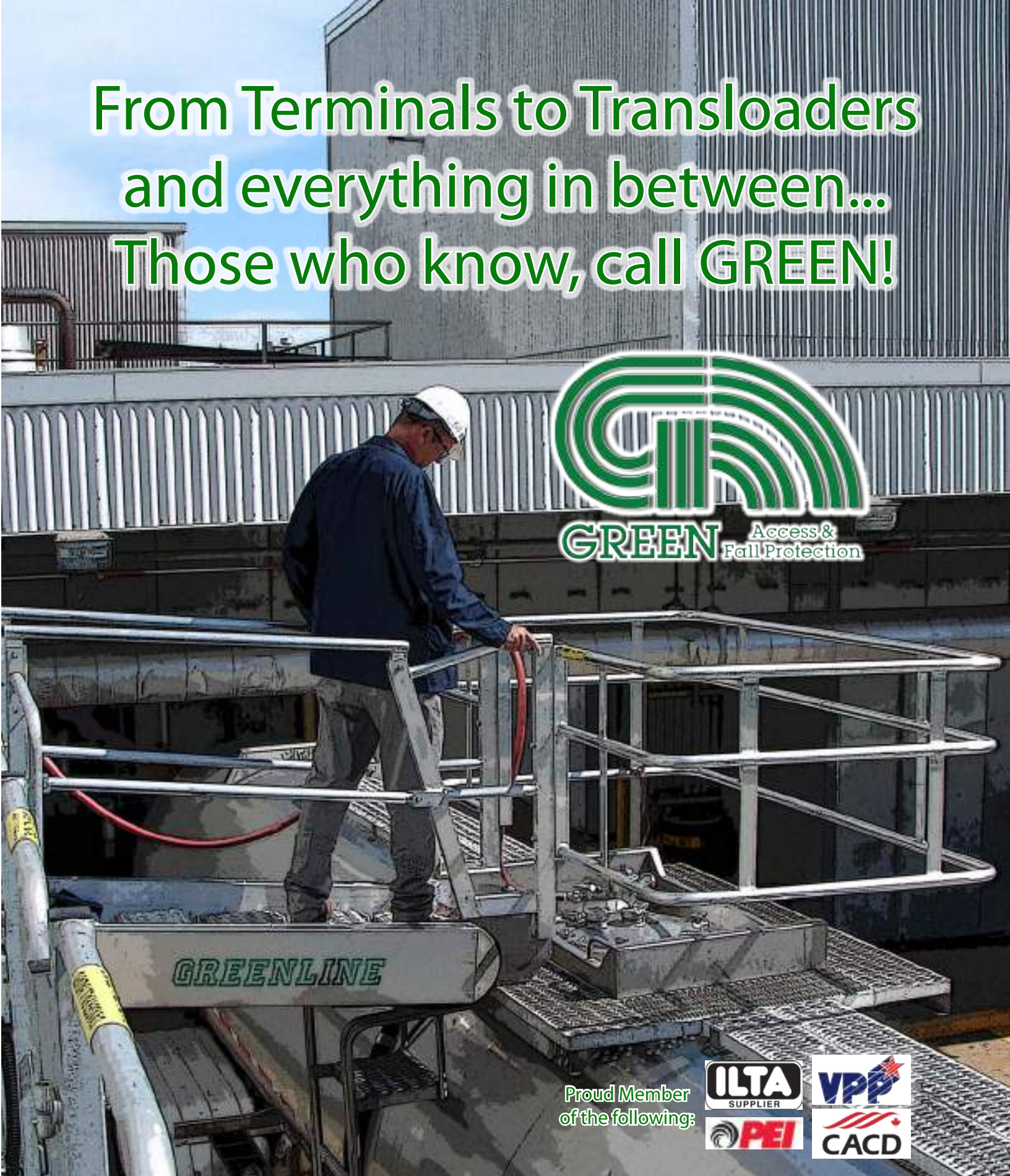

Proud Member
of the following:



Manufactured by:

BENKO PRODUCTS
ENGINEERED TO BE MORE

Benko Products Inc. · 5350 Evergreen Pkwy · Sheffield Village, Ohio · 44054
Phone (440) 934-2180 · Fax (440) 934-4052 · e-mail: sales@benkoproducts.com

--- www.BenkoProducts.com ---