



## 'Insta-Rack' Pedestal Platform

GREEN Insta-Rack Pedestal Platforms provide safe access and fall protection to the tops of single-dome tank / bulk trucks, tank cars and hopper cars.

All Insta-Racks come equipped with a single pedestal platform, access stairway and access equipment. A four-column support design is also available with integrated loading arm support.



### Features

GREEN 'Insta-Rack' Pedestal Platforms have many unique features:

- Standard designs for Railcar and Tank Truck applications
- Quick and easy assembly
- Single or double-sided access
- May be equipped with static, pivot, or 'Slide-track' mounting
- Various integration options with loading arms, piping, skid systems, and more



### Access Equipment

Various access options include:

- All gangway models
- 'Slide-track', pivot, or fixed mounting
- Custom designed safety cages or horizontal lifeline systems

### Materials / Finishes

- Galvanized steel standard
- Aluminum available
- Red oxide primer
- Gray / Yellow enamel or Custom



### 'Removable Insta-Rack'

For situations requiring more flexibility, our 'Removable Insta-Rack' features a counter-weighted base design, eliminating the need for a permanent foundation. Ask your sales representative for more information.

### Engineering

Custom designed units are available. Contact us for more information on getting started today!

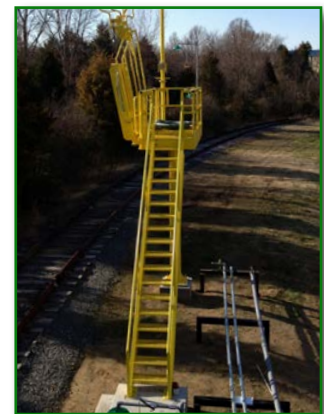

Manufactured by: **BENKO PRODUCTS**  
ENGINEERED TO BE MORE

Benko Products Inc. · 5350 Evergreen Pkwy · Sheffield Village, Ohio · 44054  
Phone (440) 934-2180 · Fax (440) 934-4052 · email: sales@benkoproducts.com  
---- [www.BenkoProducts.com](http://www.BenkoProducts.com) ----



# 'Insta-Rack' Pedestal Platform

*Always confirm unit dimensions with your sales representative prior to ordering!*

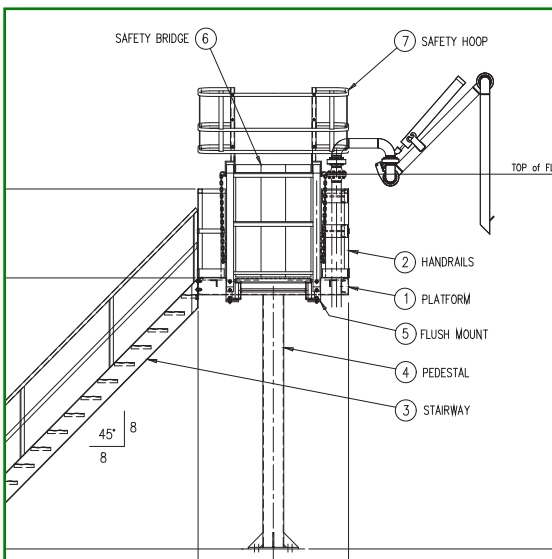

Contact us for more information on a custom solution for your application!

**BENKO PRODUCTS**  
ENGINEERED TO BE MORE

**WARRANTY:** All products manufactured by Benko Products, Inc. have a one (1) year warranty (unless otherwise specified) from the date of shipment against defects in workmanship or material. Any part or component, except items covered by warranties of other manufacturers, returned to the factory or service center freight prepaid by the owner, found upon examination by Benko Products, Inc. to be defective or the result of improper workmanship by the factory will be repaired or replaced without charge and returned to the owner freight prepaid by Benko Products, Inc. Any alterations of Benko Products, Inc. products void any warranty or liability on the part of Benko Products, Inc. Benko Products, Inc. does not guarantee product capacity if alterations are made.