

Gangway Model SB: Flat Ramp

GREENLINE Flat Ramp Gangways are specifically designed for various industries and applications that require accessing the top of a vehicle.

Most popular for accessing the tops of various Tank Truck trailers, our proven design is perfect for applications where the required range is within 15 degrees above or below the working platform height.

- **Cost Effective • Innovative Designs •**
- **Built-to-last! •**

Features

GREENLINE Flat Ramp Gangways have many unique features:

- More than 50 years in the field!
- **Spring counter-balanced for easy raising and lowering, manually!**
- Standard models up to 8' long or 6' wide. Custom dimensions also available upon request.
- Available with or without various safety cages, telescoping extensions, adjustable chain stops, and pull-up ropes
- Grip-strut tread standard
- Heavy-duty 1/2" bumpers protect vehicle from damage

Working Range

Working range is within 15 degrees above or below the platform height

--- See Range Chart on next page.

Safety Cages / Enclosures

- All gangway models available with or without a Safety Cage attached
- Standard Tank Truck and Railcar designs including 2, 3, or 4 rails
- Custom designed enclosures available to meet your specific application

Materials / Finishes

'Built-to-Last' rugged construction:

- Uncoated Aluminum or Carbon Steel models standard. All models include steel box-sections and back uprights
- Epoxy coated or hot dipped galvanized (steel)
- Galvanized steel adjustable chains
- Grip-strut tread standard. Fiberglass tread (FRP) also available
- Anodized coatings, Polyurethane paint systems, or customer supplied paint specifications accommodated.

Expedited Delivery Available

Contact your sales representative for more details and eligibility

Mounting / Installation

Simple, bolt-up assembly for quick and easy installations and replacements.

- Can be "side" or "top" mounted
- 'Slide-Track' rolling carriage systems available for horizontal tracking
- Pivot mounts for all models avail.

Engineering

Custom designed units are available to meet the most challenging applications

Options

- **Larger models may require the use of a pneumatic or hydraulic lift packages**
- Telescoping models also available (pages 6-7)

Manufactured by: **BENKO PRODUCTS**
ENGINEERED TO BE MORE

Benko Products Inc. · 5350 Evergreen Pkwy · Sheffield Village, Ohio · 44054
Phone (440) 934-2180 · Fax (440) 934-4052 · email: sales@benkoproducts.com

--- www.BenkoProducts.com ---



Gangway Model SB: Flat Ramp

Always confirm unit dimensions with your sales representative prior to ordering!



Newly redesigned box-sections and front uprights on all gangway models:

- Improve stability during use
- Reduce installation time
- Extend product life

Expedited Delivery Available!

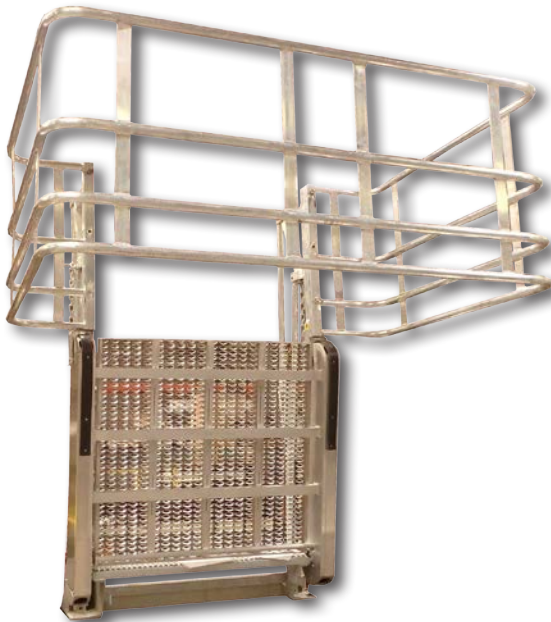
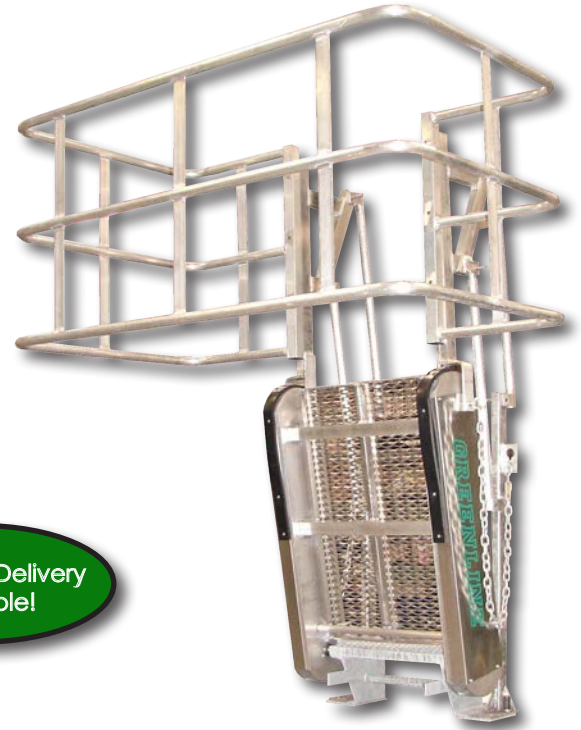

Range when Side-Mounted

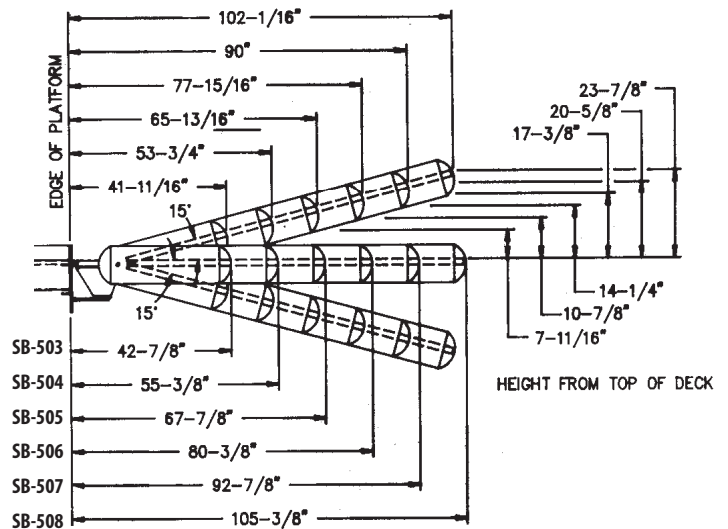

* (Aluminum model numbers shown. For steel, replace "SB-50#" with "SB-30#")

Standard models up to 8 feet long or 6 feet wide. Telescoping extensions, custom lengths, custom widths, and custom safety cages available.

BENKO PRODUCTS
ENGINEERED TO BE MORE

WARRANTY: All products manufactured by Benko Products, Inc. have a one (1) year warranty (unless otherwise specified) from the date of shipment against defects in workmanship or material. Any part or component, except items covered by warranties of other manufacturers, returned to the factory or service center freight prepaid by the owner, found upon examination by Benko Products, Inc. to be defective or the result of improper workmanship by the factory will be repaired or replaced without charge and returned to the owner freight prepaid by Benko Products, Inc. Any alterations of Benko Products, Inc. products void any warranty or liability on the part of Benko Products, Inc. Benko Products, Inc. does not guarantee product capacity if alterations are made.